

SJ1 closed: Anode = 5V  
 direct switching  
 only for VCC=5V  
 R5 = 100 -> ca. 17mA Backlight

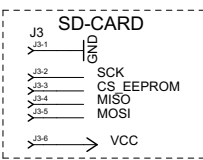

10.08.2009 RTS und CTS added  
 01.04.2010 Change package of AT90CAN  
 03.05.2010 added SJ1 - Anode to VCCINT

Gateway V1.2  
 31.12.2010 11:38:52

(c) W. Kufer, 2008 www.opendcc.de

Sheet: 1/3

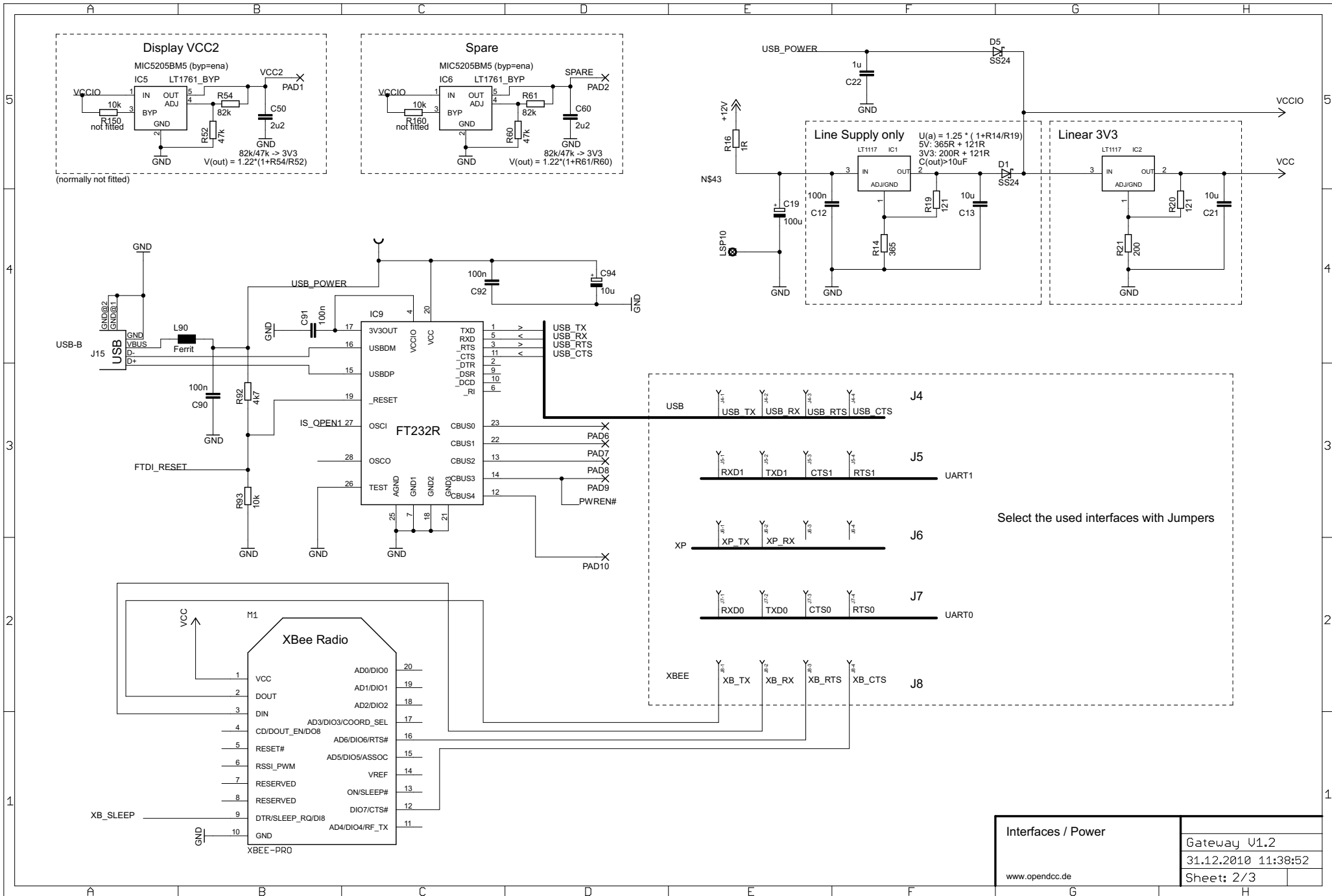

Interfaces / Power	Gateway V1.2
	31.12.2010 11:38:52
	Sheet: 2/3

www.opendcc.de

BiDi-Detector

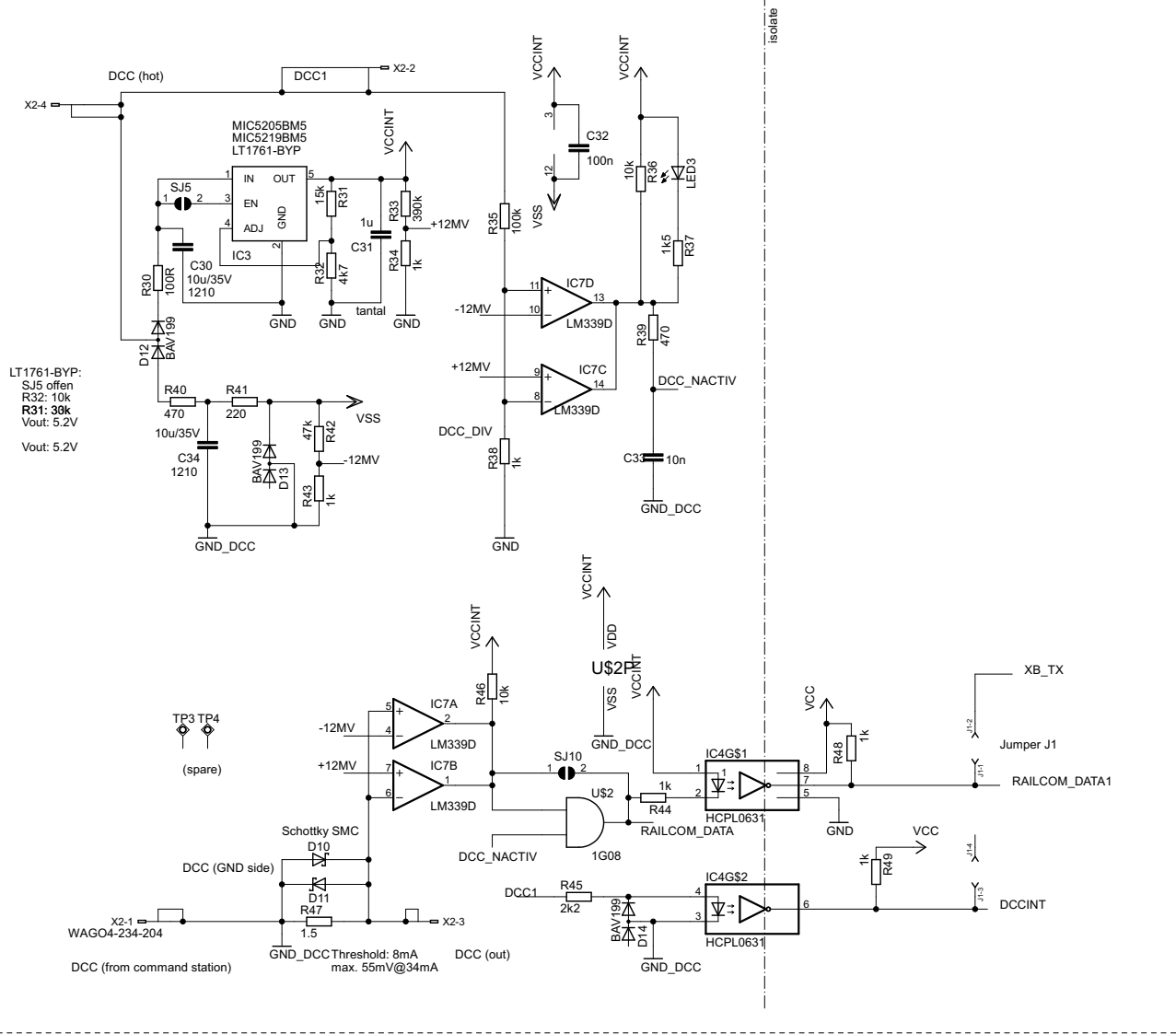

DCC/BiDi Detector	Gateway V1.2
	31.12.2010 11:38:52
	Sheet: 3/3